

MAGNIFICATION VS REFRACTION

	Magnification	Refraction
Definition	<ul style="list-style-type: none"> Magnification refers to the enlargement of the appearance of an object 	<ul style="list-style-type: none"> Refraction occurs when light travels through an area of space with a changing index of refraction.
Application	<p>A convex lens, like a magnifying glass, is commonly used to achieve magnification.</p>	<p>Devices like lenses take advantage of refraction. There are two main types of lenses:</p> <ol style="list-style-type: none"> Convex lenses: These cause parallel light rays to converge, allowing magnification. Concave lenses: These cause parallel light rays to diverge.

Example

COMPOUND MICROSCOPE

BYJU'S

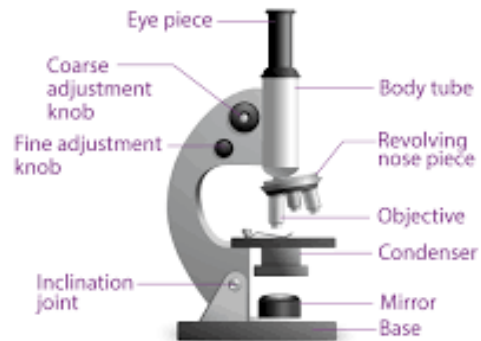

Refraction of Light

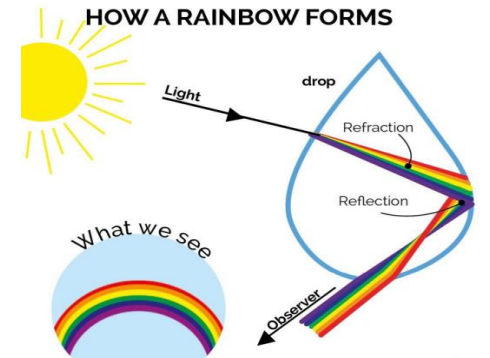
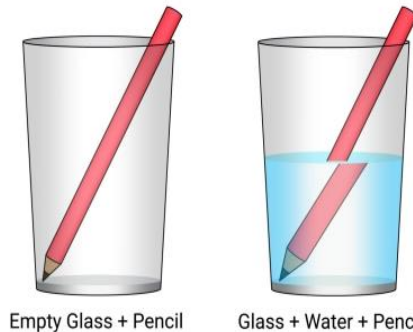

CONVEX LENS VS CONCAVE LENS

	Convex Lens	Concave Lens
Shape	<ul style="list-style-type: none"> A convex lens is thicker in the middle and thinner at the edges 	<ul style="list-style-type: none"> A concave lens is thinner in the middle and thicker at the edges
Curvature	<ul style="list-style-type: none"> The curve of a convex lens is outward-facing 	<ul style="list-style-type: none"> The curve of a concave lens is inward-facing
Focal Length	<ul style="list-style-type: none"> It has a positive focal length 	<ul style="list-style-type: none"> It has a negative focal length.
Incident Rays	<ul style="list-style-type: none"> Convex lenses converge incident rays towards the principal axis. 	<ul style="list-style-type: none"> Concave lenses diverge incident rays away from the principal axis.
Image Formation	<ol style="list-style-type: none"> When an object is placed beyond the focal point, a real, inverted, and smaller image forms between the lens and the object. If the object is placed at the focal point, the image is formed at infinity. For an object between the focal point and the lens, the image is inverted, real, and larger. When the object is on the same side as the lens, the image is upright, virtual, and larger. 	<ul style="list-style-type: none"> Regardless of the object's position, the image formed by a concave lens is upright, virtual, and smaller.
Application	<ul style="list-style-type: none"> Glasses, telescopes, spy holes in doors, and for correcting long-sightedness. 	<ul style="list-style-type: none"> Concave lenses are used in cameras, overhead projectors, project microscopes, simple telescopes, and for correcting short-sightedness.

APPLICATION OF MAGNIFICATION IN MICROSCOPE

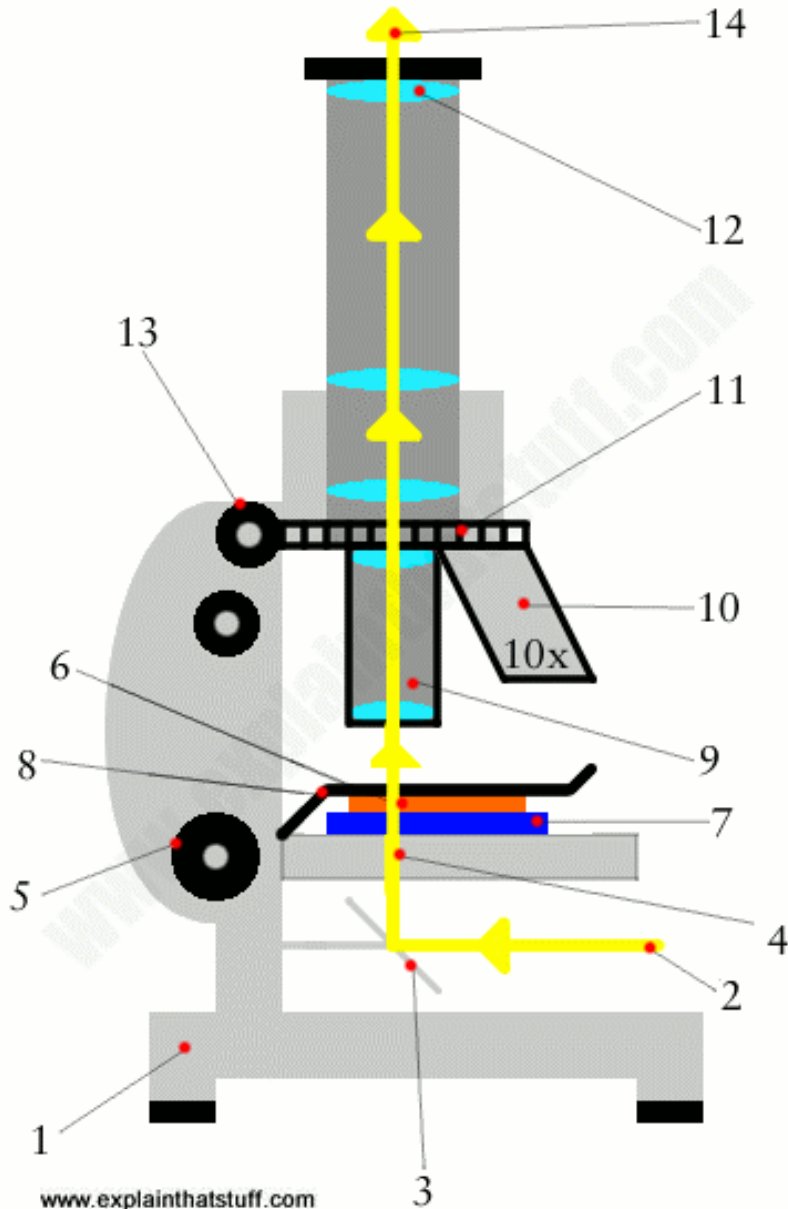

1. Placed microscope on flat surface

2. Light shines in at the bottom from light bulb

3. Light rays from an angled mirror travel straight up towards the specimen

4. The light rays pass through a hole in an adjustable horizontal platform called the stage.

8. The slide is held in place by two metal clips, one on either side.

7. Place the specimen on a glass slide and cover it to secure it.

6. Prepare a specimen to examine under a microscope.

5. Raising and lowering the stage moves the lenses closer or farther from the object, adjusting image focus.

9. Mirror light travels through glass slide, specimen, and cover slip to the objective lens closest to the object and creates the first magnification

10. A selection of other objective lenses can be used to magnify the specimen

11. The thumb knob is used to swing the other lenses into position.

12. The eyepiece lens magnifies the image from the objective lens

14. Enlarged image is observed!

13. Move the eyepiece up and down by turning the knob to adjust the focus.